



This manual contains important warnings and information.
READ AND KEEP FOR REFERENCE.

INSTRUCTIONS

Pressure Roller Attachment

Model 245907, Series C

- 9 in. (23 cm) roller frame with 45° angle and 12 in. reach
- 1/2 in. (13 mm) nap roller cover

*3600 psi (24.8 MPa, 248 bar) Maximum Fluid Inlet Pressure **

- * The best operating pressure is the lowest pressure that provides an even paint supply to the roller and typically does not exceed 300 psi (2.1 MPa, 21 bar).



CAUTION

Never leave water in the pump, gun, or pressure roller. Doing so could cause corrosion and damage from freezing. For storage, flush the system with Graco Pump Armor™ or mineral spirits/paint thinner.







GRACO INC. P.O. BOX 1441 MINNEAPOLIS, MN 55440-1441

©COPYRIGHT 2002, GRACO INC.

Graco Inc. is registered to I.S. EN ISO 9001

Warnings and Cautions

⚠ WARNING

 <p>INSTRUCTIONS</p> 	<p>EQUIPMENT MISUSE HAZARD Misuse can cause the equipment to rupture or malfunction and result in serious injury. To help prevent injury</p> <ul style="list-style-type: none"> • Do not modify the extension tube or roller frame or use parts not designed for this equipment. • Do not use 1,1,1-trichloroethane, methylene chloride, other halogenated hydrocarbon solvents or fluids containing such solvents in this or any other pressurized aluminum equipment. Such use could result in a chemical reaction, with the possibility of explosion.
	<p>FIRE AND EXPLOSION HAZARD Improper grounding, poor ventilation, open flames or sparks can cause a hazardous condition and result in a fire or explosion and serious injury. To help prevent injury from fire or explosion</p> <ul style="list-style-type: none"> • Provide fresh air ventilation to avoid the buildup of flammable fumes from flushing fluids or the coating being applied. • Keep the application area free of debris, including solvent, rags, and gasoline.
	<p>FLUID INJECTION HAZARD If high-pressure fluid pierces your skin, the injury might look like “just a cut”. But it is a serious wound. Get immediate medical attention. To help prevent injection</p> <ul style="list-style-type: none"> • Keep your hands and body away from the roller frame when flushing. High pressure fluid emitted from the holes in the frame could cause an injection injury. • Always relieve pressure before you check or repair leaks and when you turn off pump or stop painting. • Never use components rated less than system <i>Maximum Working Pressure</i>.
	<p>ELECTROCUTION HAZARD Failure to observe the electrical hazards described below could result in serious injury, including burns or electrocution. To help prevent harmful electrical shock</p> <ul style="list-style-type: none"> • Avoid contact with power lines. • Follow all grounding instructions in your separate pump and gun instruction manual, and comply with all local, state, and national fire, electrical, and safety regulations. • Use only MAGNUM or Graco paint hoses.

Pressure Relief Procedure

WARNING



psi/MPa/bar

To help prevent injection injuries, follow this procedure whenever you stop painting.

1. Engage gun trigger safety latch.
2. Shut off power to pump.
3. Turn prime/spray valve to the PRIME to relieve pressure in system.
4. Remove gun trigger safety latch. Trigger gun to relieve any pressure in hose.
5. Engage gun trigger safety latch. Keep pump prime/spray valve in PRIME position until you paint again.

Operation

1. Follow pump priming instructions prior to assembling roller.
2. Do not put tip and guard on spray gun.
3. Turn prime/spray valve to SPRAY.
4. Turn pressure control to lowest setting or roller symbol. Fig. 1.

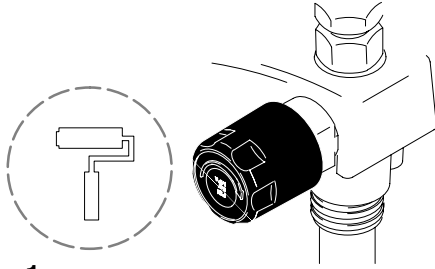

Fig. 1

5. Remove gun trigger safety latch. Trigger the gun once until paint comes out of gun. Release trigger.
6. Engage gun trigger safety latch.
7. Assemble the pressure roller as shown in the Parts Drawing, page 7. Make sure the gasket (6) is in place in bottom of roller frame as shown.
8. Attach pressure roller assembly to spray gun.
9. Rest roller on flat surface and align gun with roller. Tighten nut with wrench while keeping gun and roller aligned as pictured below.



10. Remove gun trigger safety latch. Trigger gun. Roll surface.

NOTE: Trigger the gun briefly only when you need more paint. Determine how often you must trigger the gun to maintain an even paint supply to the roller.

The best operating pressure is the lowest pressure that provides an even paint supply to the roller and typically does not exceed 300 psi (2.1 MPa, 21 bar).

11. Increase pump pressure only if triggering gun cannot supply enough paint for your rolling speed.



Pressure Relief Procedure, page 3.

12. Whenever you stop painting, **relieve the pressure**, and elevate roller end of extension tube to prevent paint from draining out.

Flush the pump, gun, and pressure roller immediately after each use to prevent paint from drying in the pressure roller and damaging it. (Cleaning, page 6).

Rolling Techniques

1. Rolling vertically, roll out the letter "M". (Fig. 2.)

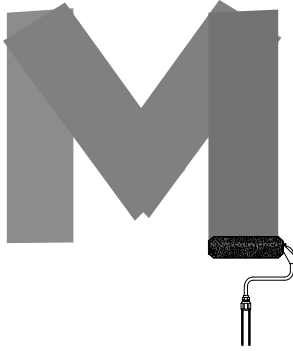

Fig. 2

2. Cross roll, horizontally, to spread paint. (Fig. 3.)

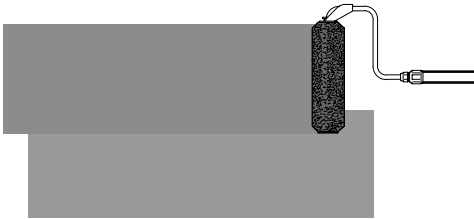

Fig. 3

3. Finish with light, vertical strokes until the entire area has been covered, evenly. (Fig. 4.)

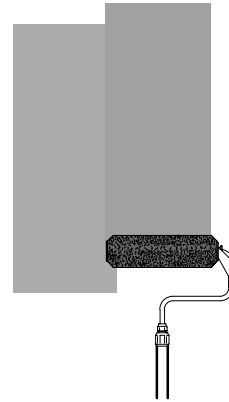

Fig. 4

Ceilings, Walls, and Woodwork

1. **Ceilings:** Using a paint brush, apply a starting row of paint approximately the width of your paint brush where the walls and ceiling meet. (Fig. 5.)

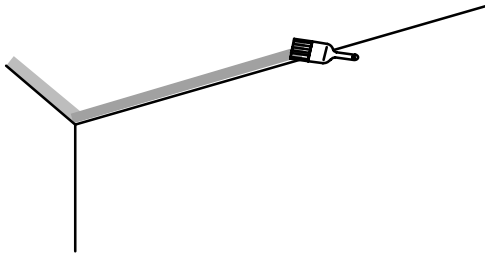

Fig. 5

2. With the roller, apply paint to the ceiling, working the short way of the room and applying as wide a strip as possible. (Fig. 6.)

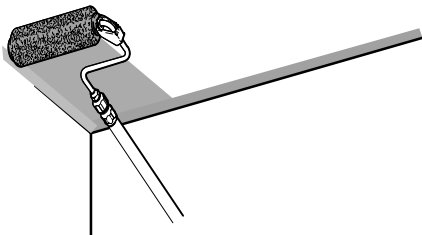

Fig. 6

1. **Woodwork & Walls:** Using a brush, paint woodwork first. Apply a starting row of paint approximately the width of the paint brush around the woodwork and where the walls meet the ceiling. (Fig. 7.)

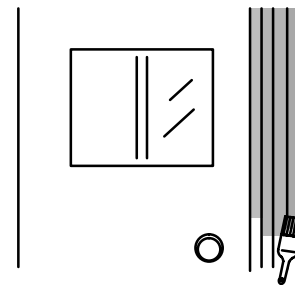

Fig. 7

2. With the roller, apply paint to the walls, following the Roller Techniques described above. (Fig. 8.)

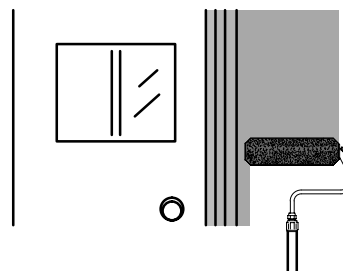

Fig. 8

Cleaning

This is the procedure for flushing the pressure roller. The pump and gun you are using may have additional flushing steps, such as cleaning filters and screens. See the pump and gun flushing instructions.

NOTE: Leave the pressure roller attached to the gun for this procedure.



Pressure Relief Procedure, page 3.

1. **Relieve the pressure.**
2. Remove roller cover (7) and diffuser (4) from roller frame as follows (Parts Drawing, page 7):
 - a. Using your thumb, press down on clip (5) to release end caps (2 & 3), diffuser (4) and roller cover (7) into a pail.
 - b. Remove roller cover (7) from diffuser (4).
 - c. Pull end caps (2 & 3) off diffuser (4). Disassemble.
3. Clean roller cover (7), caps (2 & 3) and diffuser (7) with water or a compatible fluid for oil-based materials.
4. Place roller frame (1) in paint pail. Be sure the holes in roller frame (1) are facing inside the paint pail.
5. Prime pump with water or flushing fluid for oil-based materials. Use the lowest pump priming pressure setting.
6. Turn prime/spray valve to SPRAY.

NOTE: Perform Step 7 at the lowest pressure possible.
7. Trigger gun until flushing fluid begins to dilute the paint.
8. Place roller frame (1) in another bucket and continue flushing until fluid coming out of the roller frame (1) is clear.
9. Shut off the pump. Turn prime/spray valve to PRIME.

Storage

If you are going to store the airless equipment for an extended period of time after flushing with water-base fluid, flush again with Graco Pump Armor or mineral spirits/paint thinner. Leave the fluid in the system during storage.

Roller Parts

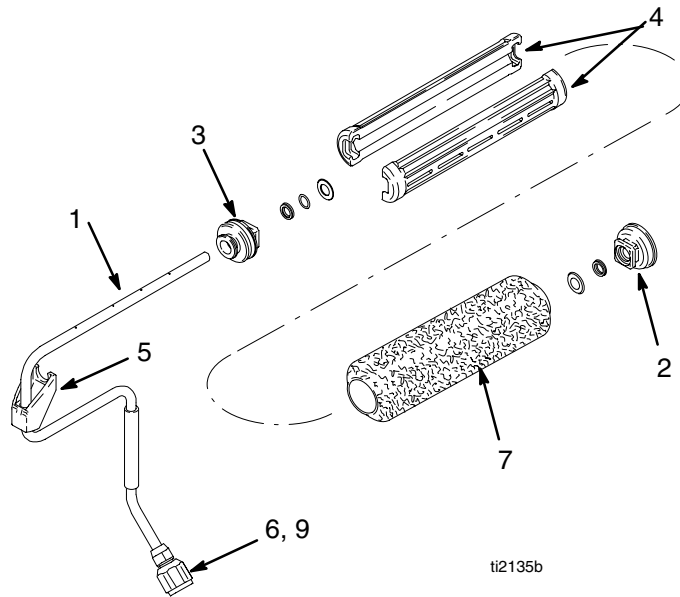

Parts List

Ref. No.	Part No.	Description	Qty.
1		FRAME, roller	1
2	245999	CAP, end (includes seal and retainer)	1
3	246277	CAP, end (includes seal and retainer)	1
4	15B065	DIFFUSER	2
		o-ring)	1
5	197106	CLIP, roller	1
6	115524	GASKET	1
7	186678	ROLLER, cover, 9 inch, 1/2 in. (13 mm) nap	1
9	197118	SWIVEL, fitting	1

Additional Roller Covers

For the best coverage it is important to choose the right roller cover nap for the surface you are rolling. For rougher surfaces choose a thicker nap. Use a thinner nap on smooth surfaces.

Part No.	Nap Size	Surface Texture/ Example	Material
243063	9 in. (23 cm); 1/2 in. (13 mm)	Smooth/ metal, wood, trim, drywall	medium
243064	9 in. (23 cm); 3/4 in. (19 mm)	Rough/ cement, brick	heavy
243065	9 in. (23 cm); 1-1/4 in. (32 mm)	Extra-rough/ cement block, tex- tured walls, ceil- ings	heavy

Limited Warranty

Graco Inc. warrants to the original retail purchaser (other than for purposes of resale or rental) all equipment manufactured by Graco and bearing its name to be free from defects in material and workmanship if operated in accordance with Graco's printed recommendations and instructions. This warranty applies for one year from the date of purchase.

This warranty does not cover and Graco shall not be liable for general wear and tear, or any malfunction, damage or wear caused by improper use, accidents, user negligence, use of non-Graco component parts or service or repair performed by anyone other than a Graco authorized service center.

IMPLIED WARRANTIES, INCLUDING THOSE OF MERCHANTABILITY AND FITNESS FOR A PARTICULAR PURPOSE, ARE LIMITED TO ONE YEAR FROM THE DATE OF ORIGINAL PURCHASE.

GRACO SHALL NOT IN ANY EVENT BE LIABLE FOR ANY INCIDENTAL, INDIRECT, OR CONSEQUENTIAL LOSS, DAMAGE OR EXPENSE OF ANY KIND, WHETHER FROM BREACH OF THIS WARRANTY OR ANY OTHER REASON. Some states do not allow the exclusion or limitation of incidental or consequential damages, so the above limitation or exclusion may not apply to you.

To make a claim under this warranty, return the product with proof of purchase, transportation prepaid, to any Authorized Graco Service Center. Graco's Authorized Service Center, at its option, will either repair or replace the product and return it to you, postage prepaid. A listing of Authorized Graco Service Centers is enclosed with this product. You may also find the nearest Authorized Graco Service Center by calling 1-888-541-9788 or by visiting our website at www.graco.com.

This warranty gives you specific legal rights and you may also have other rights which may vary from state to state.

*All written and visual data contained in this document reflect the latest product information available at the time of publication.
Graco reserves the right to make changes at any time without notice.*

GRACO INC. P.O. BOX 1441 MINNEAPOLIS, MN 55440-1441
www.graco.com

PRINTED IN USA 309511 4/2002, Revised 4/2003